

PART 1 – GENERAL ORGANISATION OF CYCLING AS A SPORT

Rules amendments applying on **01.01.2021**
update on **25.09.2020**

Chapter II RACES

Section 1: administrative provisions

§ 1 Calendar

- 1.2.012** The inclusion of a race on the international calendar shall be subject to the payment of a fee, called the calendar fee, the amount of which shall be set annually by the UCI management committee.

The total amount of the fee must be paid by the organiser to the UCI upon reception of an invoice from the UCI. Invoices are sent 90 days before an event, or upon approval of the race in the calendar, whichever is later. ~~no later than two months after the meeting of the management committee at which the calendar for the discipline in question is approved. The above deadline is the date on which the UCI account must be credited.~~

~~In case of delay, a penalty of CHF 100 for each started month will automatically be applied.~~

The UCI reserves the right to remove the race from the international calendar at any moment prior to the event should the calendar fee remain unpaid. In such a circumstance, no UCI International Commissaires will be appointed, respectively no UCI ranking points will be awarded to the participants; should the organiser wish to re-register the event on the calendar on a following season a penalty fee of CHF 250 will be applied.

~~The inclusion of the race on the following calendar shall be refused should the fee, as well as the penalty not have been paid one month before the meeting of the management committee at which the calendar in question is approved.~~

Furthermore, a race inscription shall be refused if the enrolment fees for previous **season's** races have not been paid or if the organiser does not honour its financial obligations with the UCI. This measure also applies to the new organiser of the race and, in general, to the organiser and/or race that the management committee considers to be the successor of another organiser or another race.

(text modified on 01.06.98; 01.02.03; 01.01.04; 01.01.05; 01.01.21)

§ 5 Sanction

~~1.2.024~~ The result of each race shall be sanctioned by the national federation of the organiser as fast as possible after the end of the competition.

(text modified on 01.01.98; 01.01.05)

[article abrogated on 01.01.21]

~~1.2.025~~ National federations shall make absolutely sure that the results of the race are not being contested before sanctioning them.

[article abrogated on 01.01.21]

Section 2: organisation of races

(numbering of articles modified on 01.01.05)

§ 5 Invitation – Enrolment

General provisions

1.2.052 National, regional and club teams and their respective riders may not start in competitions abroad unless they hold authorisation in writing issued by their federation (except teams and riders from the same federation as the event organiser). This authorisation must carry the dates of validity and the name(s) of the rider(s) concerned. The provisions in this article shall not apply to riders covered by the provisions of article 2.1.011.

The provisions in this article shall not apply to riders participating in cyclo-cross **Mountain Bike, BMX and BMX Freestyle** events.

(text modified on 01.01.01; 01.01.04; 01.01.05; 01.07.18; 01.01.21)

§ 9 Prizes

1.2.073 At any time prior to payment of prizes, if there is any dispute or ongoing proceeding that might influence placing and hence entitlement to a prize, the prize **shall** may be withheld until a decision has been reached.

~~Unless specially provided otherwise, the following riders in the classification shall each advance by one place and shall be entitled to the prizes corresponding to their new places.~~

~~Should a rider or a team lose the place that entitled him or them to a prize, the prize must be returned within one month to the organizer who shall proceed to its redistribution. In the event of non-compliance, the total amount repayable shall be increased automatically by 20% (twenty percent) and the organiser may refer the matter to the UCI. The rider or team shall be suspended automatically if the prize, increased by 20% (twenty percent), has not been repaid in the hands of the UCI within one month of notice being given by the UCI until such time as the total amount due has been repaid.~~

~~The last paragraph applies also to any intermediary or beneficiary in possession of the prize as from the moment that the request for repayment is made.~~

~~(text modified on 01.01.05; 01.10.05; 01.01.09; 01.02.19; 01.01.21)~~

Section 5: UCI cups, series and classification

~~1.2.133~~ Is omitted from any UCI classification as well as from any UCI cups and series classifications:

- ~~1. the suspended rider. However, in case of suspension until the last event counting for the ranking, the rider is immediately excluded from the classification.~~
- ~~2. the rider who may have committed an anti-doping rule violation and whose identity has been publicly disclosed under article 14.4 of the UCI Anti-Doping Rules until his definitive acquittal.~~

~~The omission means that the name of the rider does not appear in the classifications and that his place is left vacant.~~

~~(text modified on 01.09.05; 19.09.06; 01.10.09; 01.07.17)~~

[article abrogated on 01.01.21]

~~1.2.134~~ The rider found guilty of an anti-doping violation is excluded from each classification which is calculated over a period in which the violation occurred.

~~(article introduced on 01.09.05)~~

[article abrogated on 01.01.21]

Chapter III EQUIPMENT

Section 2: bicycles

§ 2 Technical specifications

c) Configuration

1.3.020 For road, ~~track competitions other than time trials~~ and for cyclo-cross competitions, the frame of the bicycle shall be of a traditional pattern, i.e. built around a main triangle. It shall be constructed of straight or tapered tubular elements (which may be round, oval, flattened, teardrop shaped or otherwise in cross-section) such that the form of each element except the chain stays and the seat stays encloses a straight line. The elements of the frame shall be laid out such that the joining points shall follow the following pattern: the top tube (1) connects the top of the head tube (2) to the top of the seat tube (4); the seat tube (~~from which the seat post shall extend~~) shall connect to the bottom bracket shell; the down tube (3) shall connect the bottom bracket shell to the bottom of the head tube. The rear triangles shall be formed by the chain stays (6), the seat stays (5) and the seat tube (4) with the seat stays anchored to the seat tube at points falling within the

limits laid down for the slope of the top tube. (See diagram «Shape (1)»). The seat post shall comply with the dimensional restrictions that apply to the seat tube and may be attached to the frame anywhere on the seat tube and/or top tube. (See diagram «Shape (2)»).

The maximum height of the elements shall be 8 cm and the minimum thickness 1 cm. ~~The minimum thickness shall be reduced to 1 cm for the chain stays (6) and the seat stays (5).~~ The minimum thickness of the elements of the front fork shall be 1 cm; these may be straight or curved (7). (See diagram «Shape (1)»).

The top tube (1) may slope, provided that this element fits within a horizontal template defined by a maximum height of 16 cm ~~and a minimum thickness of 2.5 cm.~~

The effective width of the head tube zone may not exceed 16 cm at the narrowest point between the inner join of the top tube and down tube and the front of the box for the head tube.

Additional frame components can be added between the head tube and the handlebar stem. These must be inside the dimension of the head tube box.

Isosceles compensation triangles with two 8 cm sides are authorized at the joints between frame elements except at the joints between the chain stays and seat stays where triangles are not authorised (See diagram «Shape (3)»).

(text modified on 07.06.00; 01.01.05; 01.02.12; 01.01.16; 01.01.21)

Position of boxes and laid out

Shape (1)

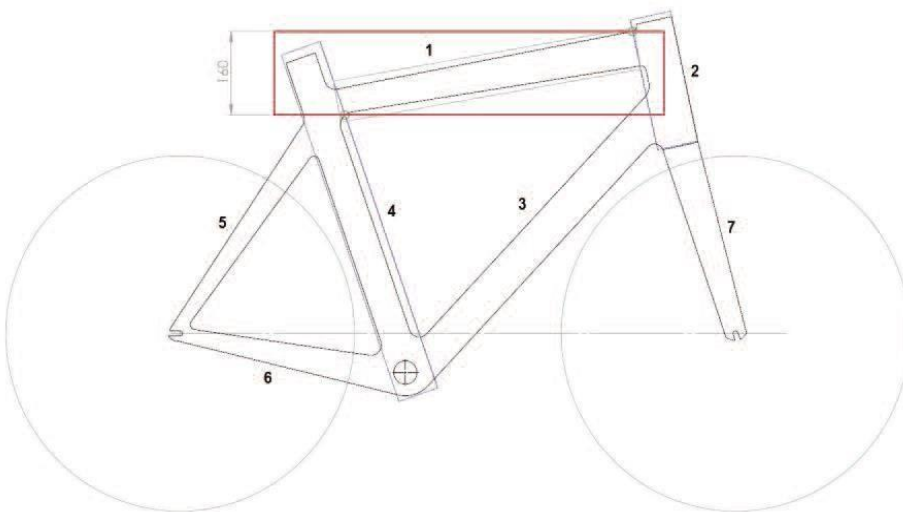
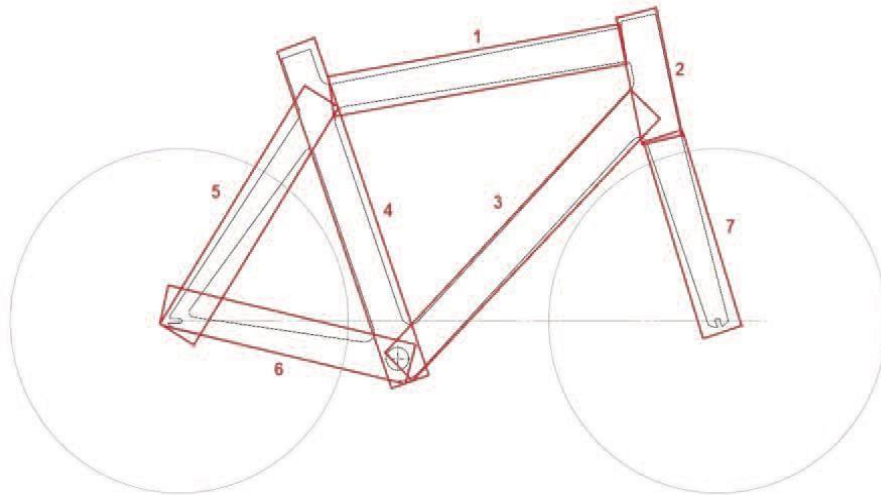

Tubes 1,2,3,4,5,6,7: 1cm minimum & 8cm maximum

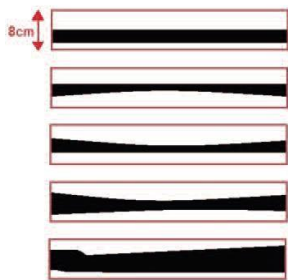

Éléments tubulaires droits ou étirés

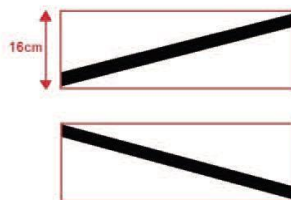

Inclinaison du tube horizontal



Une ligne droite devant s'inscrire à l'intérieur de l'élément

Position of the seat post box

Shape (2)

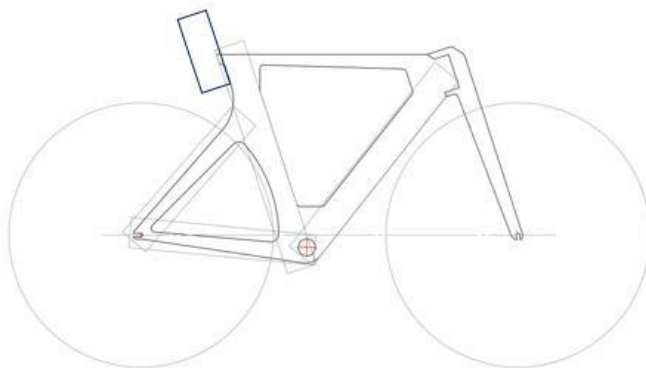
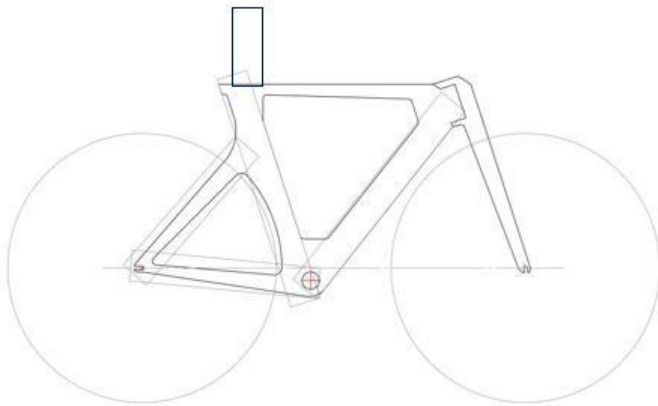
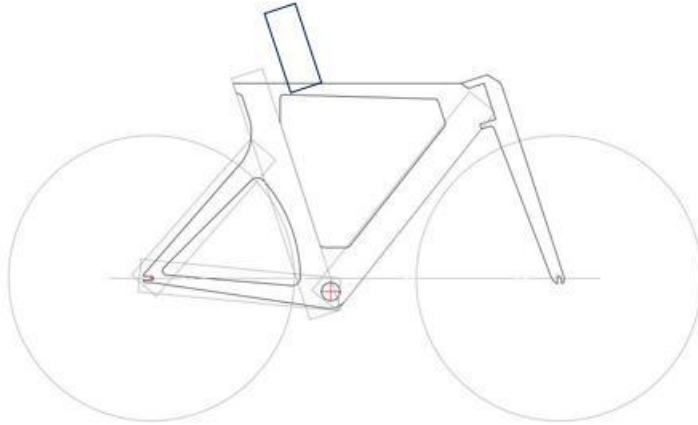

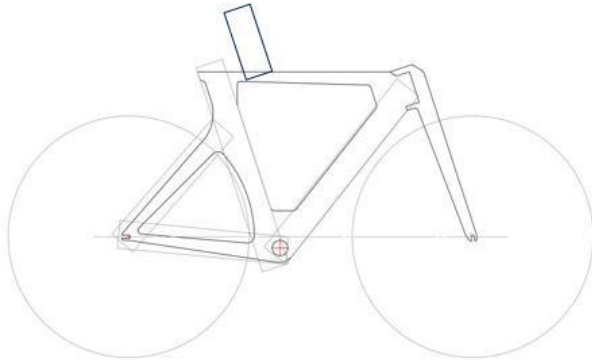

Position of compensation triangles

Shape (3)

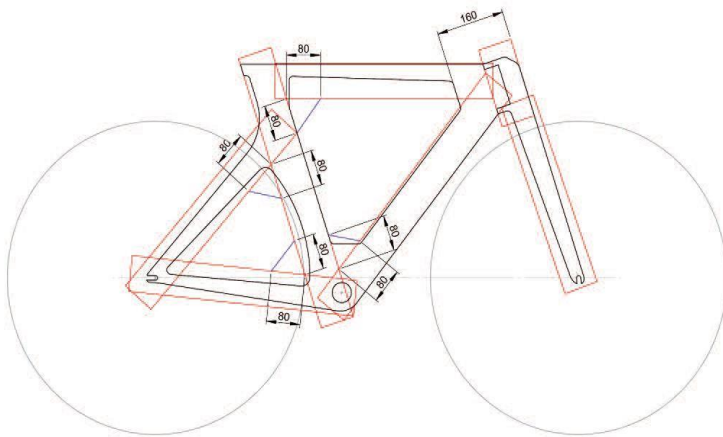

1.3.021 ~~For road time trials and for track competitions:~~

- ~~— the elements of the bicycle frame may be tubular or solid, assembled or cast in a single piece in any form (including arches, cradles, beams or any other). These elements, including the bottom bracket shell, shall fit within a template of the «triangular form» defined in article 1.3.020.~~
- ~~— (See diagram « Shape (2) »);~~
- ~~— isosceles compensation triangles with two 8 cm sides are authorized at the joints between frame elements except at the joints between the chain stays and seat stays where triangles are not authorised. Additionally, the compensation triangle between the top tube and down tube is replaced by a compensatory joint zone 16 cm wide delimited at its foremost by the front of the box for the head tube;~~
- ~~— the effective width of the head tube zone may not exceed 16 cm at the narrowest point between the inner join of the top tube and down tube and the front of the box for the head tube.~~

Position of boxes and compensation triangles

Shape (2)

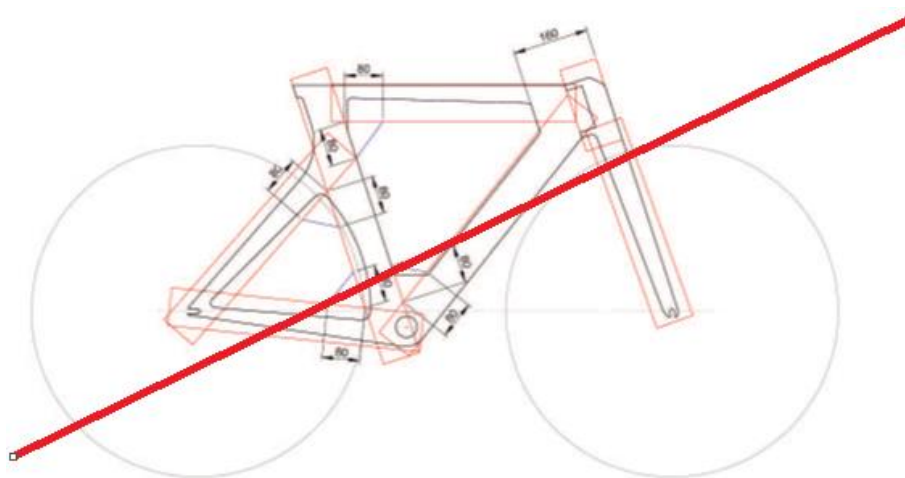

[article abrogated on 01.01.21]